

CLIMATE  
MASTERS

of SEELEY  
INTERNATIONAL

**Breezair**  
NUMBER ONE IN NATURAL COOLING



**Cool your whole home from the  
cost of running a single light globe**

THE EXCLUSIVE  
*Supercool*  
RANGE

WITH ADVANCED  
**MAGIQTOUCH**  
CONTROLLER



**SEELEY**  
INTERNATIONAL



## Frank Seeley AM FAICD

Founder and Executive Chairman.

With a history of innovation and quality, the Breezair range, manufactured by Seeley International, delivers quiet and powerful cooling that's energy efficient, so it's kind to the environment as well as to you.

The first corrosion-free, all-plastic rooftop evaporative air conditioner, and the first and only evaporative air conditioner with mega-energy-saving inverter technology, Breezair is the market leader in Australia and leads the world in evaporative cooling technology.

Breezair is one of the many leading brands manufactured by Seeley International, Australia's largest air conditioning manufacturer. 100% Australian owned, Seeley International now exports Australian-made products to well over 120 countries under the award-winning brand names Braemar, Climate Wizard, Coolair, Convoir as well as Breezair.

Today, more than ever you can trust Breezair for keeping your home cool without costing the earth, all with a comprehensive 7 year warranty\*.



Seeley International's founder and Executive Chairman Frank Seeley AM FAICD at its Adelaide factory.

## Climate Masters of Seeley International

Climate Masters of Seeley International was established to help consumers identify the best of the best in the industry.

When it comes to expertise in heating and cooling, there is no one better. That's because Climate Masters of Seeley International members are trained to deliver industry leading technology and service excellence for our customers. Gaining a Climate Masters of Seeley International membership is not easy. Only those who can comply with the rigorous requirements and are working to industry leading quality standards are eligible.

For more information and to find your nearest dealer visit:  
[www.climatemastersofsi.com.au](http://www.climatemastersofsi.com.au)

## Award winning manufacturer

### Some of Seeley International's awards...

BPN Sustainability Awards 2014  
Finalist: Innovation of the year  
MagIQtouch Controller

Sydney Design Awards 2014  
Finalist: Product Design – Home  
MagIQtouch Controller

Australian Design Awards 2014  
Good Design® Selection  
MagIQtouch Controller

For more information go to [www.seeleyinternational.com/awards](http://www.seeleyinternational.com/awards)

\*Exclusive from Seeley International dealers only.

## Cooler. Fresher. Quieter.

Your home deserves the finest ducted evaporative air conditioning available.

So it makes good sense to choose the revolutionary Breezair – the world's quietest and most efficient ducted evaporative air conditioning system.

The technology built into Breezair is the best in the world and your guarantee of the ultimate in comfort, economy and cooling power.

Breezair is now available with the new MagIQtouch Controller – featuring advanced touch screen technology.



## New Breezair Supercool®

Enjoy up to an amazing 20% more cooling this summer with new Breezair Supercool – available exclusively from your Climate Masters of Seeley International dealer.



**Supercool**  
DELIVERS UP TO 20% MORE COOLING

Install Breezair... it's the name you can trust.

“Our system has been amazing, it is so much quieter than our neighbours’. Great value for money and very economical. Received my first power bill (after the hottest summer on record) and was very pleased.”  
Michelle, WA



## Why choose evaporative air conditioning?

### Save on your electricity bill

Imagine being able to keep your family comfortably cool all summer long for as little as \$37 per year in electricity costs\*. That’s a saving of \$346 per year in electricity costs when compared to a standard efficiency ducted refrigerated system!

Wherever you live in Australia, Breezair technology will cost less to cool your home than any other comparable system.

Breezair evaporative air conditioning system is so efficient it costs less than one tenth of a standard ducted air conditioner to run.

It’s little wonder that with Breezair, you can cool your entire home from as little as the cost of running a light globe.

### 100% fresh air

Step inside a Breezair-cooled home and you’ll quickly notice how refreshingly cool it feels.

One of the major benefits of Breezair evaporative air conditioning is the way it fills your home with fresh, filtered, cool air – it’s as natural as a soothing sea breeze.

Unlike refrigerated systems, Breezair does not continually recycle stale air – it actually completely replaces the air within your home every few minutes.

### Cool both indoor and outdoor living spaces with one system

Summer is for living! For those who enjoy entertaining outdoors, for families with children, and for people who simply prefer fresh rather than recycled air, Breezair is unquestionably the best choice.

That’s because only evaporative air conditioning allows doors and windows to remain open whenever it is operating. Cooling performance is unaffected by people coming and going, which makes Breezair a perfect companion to the relaxed Australian lifestyle.

Annual Running Costs for Whole of Home Air Conditioning

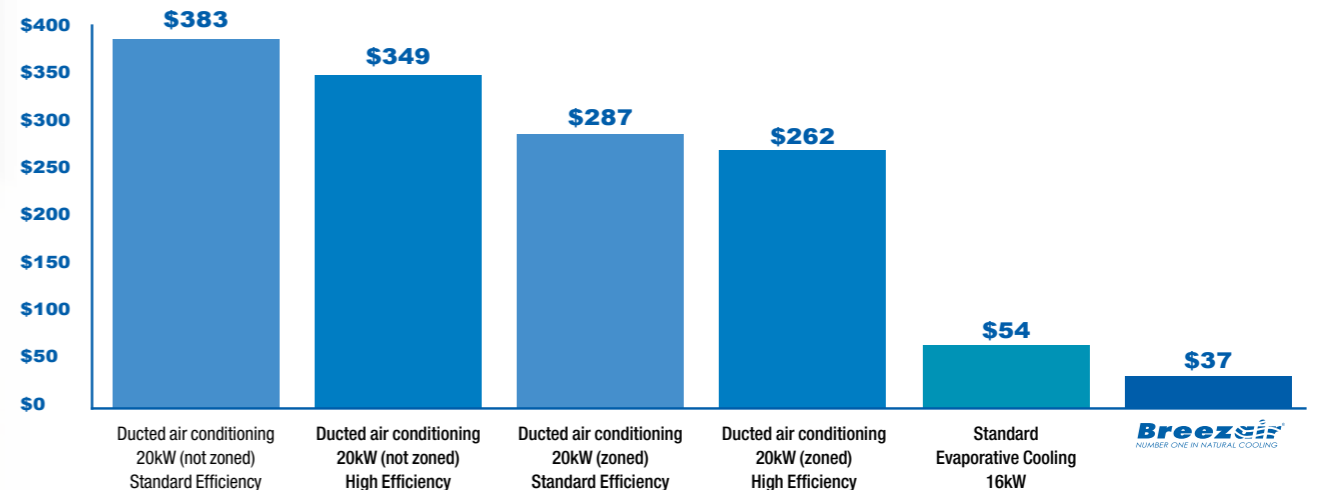

\*Based on a 166 m<sup>2</sup> home. Approximate cost per annum, based on 300 hours usage and a 60% duty cycle for air conditioners. Based on electricity tariff of 28c / kWh. Note – evaporative coolers will also use water.

Source: Sustainability Victoria, ‘Cooling Running Costs’, www.sustainability.vic.gov.au, 2013.

## Breezair... better because



Breezair evaporative air conditioning is ideal for asthmatics, children and the elderly because it continually circulates a fresh supply of clean, filtered air throughout your home.

## Why choose evaporative air conditioning?



### Look after the environment

The power consumption of just one ducted refrigerative air conditioner can result in up to 1.6 tonnes of harmful CO<sub>2</sub> being pumped into the atmosphere each year.\*

On the other hand, Breezair evaporative air conditioning system is so efficient it produces less than one tenth of this volume.

By choosing Breezair, you can help reduce the amount of harmful greenhouse emissions entering our environment.



### A healthy choice for you and your family

For air conditioning that fills your home with fresh, cool, clean air, Breezair is unquestionably your best choice.

That's because Breezair completely replaces the air within your home every few minutes. Fresh air is drawn through moistened Chillcel® pads where it is filtered and cooled before being gently circulated throughout your home.

It's a process as natural as a sea breeze, giving you continuous fresh air instead of stale, recirculated air from a refrigerated system.

It's also much gentler on the eyes, nose and skin because evaporative air conditioning doesn't have the aggressive drying effect that occurs with refrigerated systems.



**WaterMiser®** monitors water quality to reduce consumption, minimise waste and eliminate unnecessary dumping of water.

CO<sub>2</sub> Emissions for Whole of Home Air Conditioning (kg/yr)\*

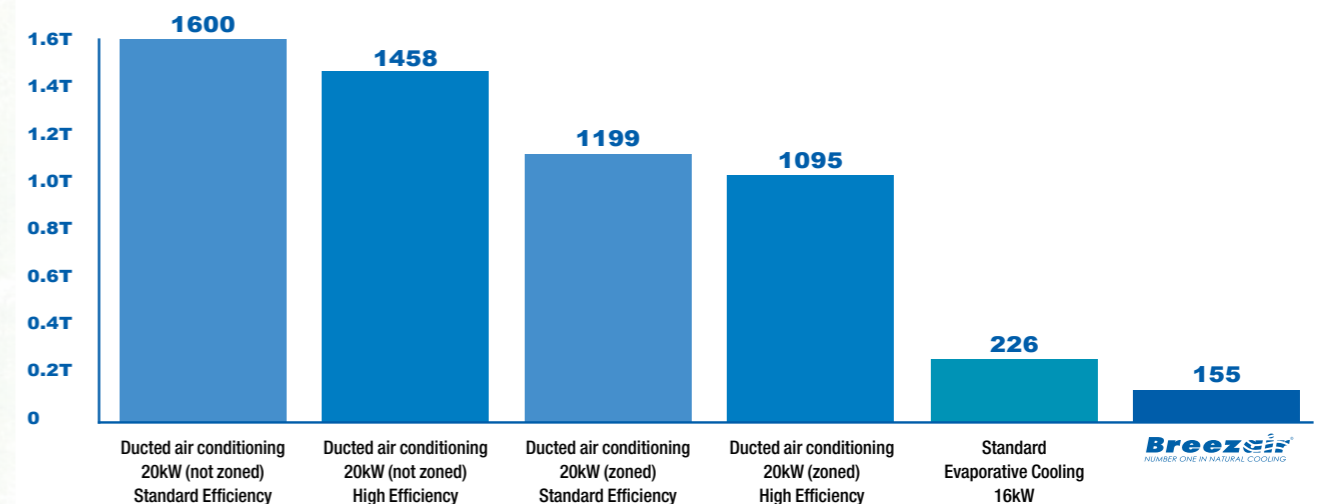

\*CO<sub>2</sub> emissions based on 1.17 kg CO<sub>2</sub> e/kWhr electricity purchased from grid for Victoria.

Source: National Greenhouse and Energy Reporting (Measurement) Determination 2008 - with amendments (schedule 1, part 6).

# Breezair

– why there is nothing else in its class!

CLIMATE  
MASTERS  
of SEELEY  
INTERNATIONAL

## Why choose a Climate Masters of Seeley International specialist?



**Save even more with the only evaporative air conditioner with InvertaCool™ inverter technology.**

Trust Breezair to be the only evaporative cooling system with mega-energy-saving InvertaCool inverter technology. Breezair's InvertaCool is an amazing innovation that saves you money on operating costs year after year, after year.

InvertaCool cleverly manages power consumption which adds up to greatly reduced energy use, improved performance and genuine cost savings... and, only Breezair has it!



**Australian made quality**

Breezair's engineering sets a new standard for cooling performance and reliability. Whether you live in Birdsville or Bondi, Breezair leading-edge cooling technology won't let you down. That's because Breezair is designed and built in Australia to withstand even the harshest Australian summer. With rugged and clever design features such as these, Breezair will keep you and your family comfortably cool for years to come...

- Corrosion-free materials
- Injection moulded cabinets and components that will not rust or fade
- UV stabilised polymers
- Long life Chillcel® pads
- Revolutionary WaterMiser® monitor
- Powerful Tornado® pump
- Amazing auto Clean and Dry function
- Anti-clog water distribution
- Now available with the new touch screen MagIQtouch Controller!



**Looks that are built to last**

Designed to blend discretely with the roofline of your home, Breezair's world renowned Permatuf® cabinets look great and won't crack, peel or warp.

Manufactured in Australia from UV stabilised polymer, the injection moulded cabinets are virtually impervious to our harsh climate and will retain their good-as-new looks year after year.



**Nothing cools as quietly**

The thing you immediately notice about the world class Breezair series is how wonderfully cool it makes your home feel, and how quietly it operates – it's incredibly quiet.

In fact nothing comes close to the unobtrusive cooling power of the Breezair series.

It's all thanks to the superior design of Breezair's ground-breaking centrifugal fan and Hushpower motor, a global revolution in air conditioning engineering.

Old-fashioned axial fan systems are noisy because they spin like helicopter blades which creates air turbulence.

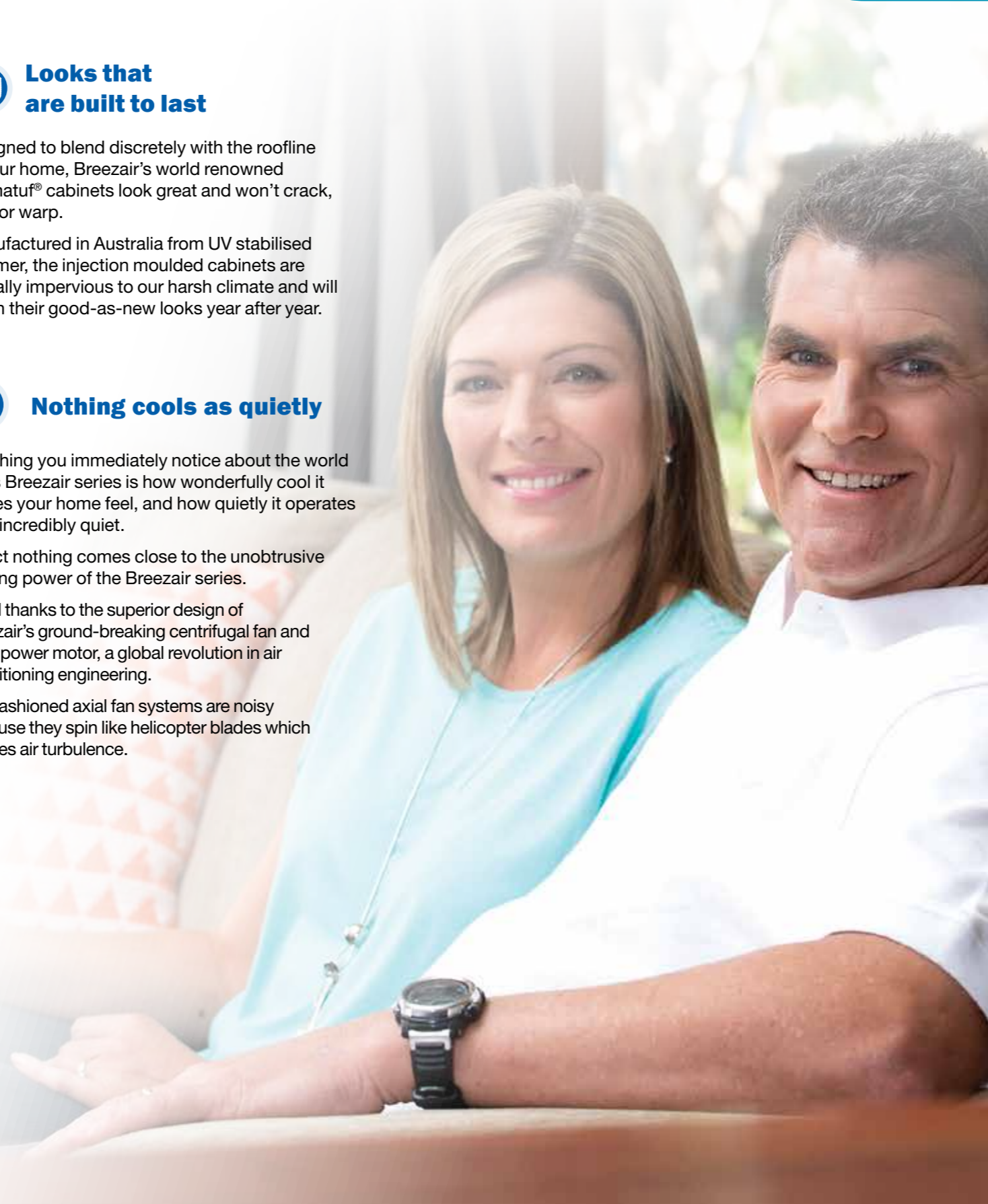

**Members of Climate Masters of Seeley International are heating and cooling experts and provide a level of service you won't get anywhere else.**



**Unsurpassed professionalism and expertise**

You get a comprehensive assessment of your cooling needs and a solution that is exactly right for you, backed up with a product recommendation from CompuComfort™. The intelligent CompuComfort design program uses a unique web application to accurately profile your home's key architectural aspects. CompuComfort considers a variety of factors such as solar and thermal gains, and insulation values; in so doing it ensures the optimum system is specified for your unique requirements. This is followed by a detailed written solution and cost quote, so you have all the information you need to guarantee that you and your family are superbly comfortable, all year round.



**Unrivalled quality service**

You get quick, professional and outstanding service, with absolutely no mess left behind, backed by our seven year workmanship warranty. Importantly all members take health and safety standards very seriously and only employ qualified tradespeople.



**Aftercare that really delivers**

Once your cooling system is operating as designed, you get as much of our time as you need to show you how to use it and how to get the most out of it, and we're here to help whenever you need us.



**Reliability**

You receive the benefit of our impeccable track record, which speaks for itself. That's the only way selected dealers can be Climate Masters of Seeley International members!



**Exclusive product offer**

Enjoy up to 20% more cooling this summer with new Breezair Supercool – available exclusively from your Climate Masters of Seeley International dealer.

# MagIQtouch Controller

## – featuring advanced touch screen technology

With the MagIQtouch Controller, operating your Breezair is a breeze. It's smart, sophisticated and intuitive. And, its sleek, modern design will meld with the décor of almost all Australian homes. You don't have to re-learn how to use this controller. Its technology is based on the same simplistic functions of other touch screens you're familiar with. It has intuitive user navigation, making the operating process simple.

With your lifestyle very much in mind, the MagIQtouch Controller has been designed to make your life a breeze, and together with your Breezair evaporative air conditioner, it will make your home a haven on hot summer days.

### Installation wizard

Upon installation of your Breezair evaporative air conditioner and MagIQtouch Controller, your installer will be taken through an Installation Wizard. This ensures your Controller is set up correctly with an easy to follow, step-by-step navigation system specifically designed to make the installation process simple.

### Program

If you like routine and want to "set and forget" a seven day program that suits your lifestyle, then Program Mode is for you.

Program Mode divides each day into four time periods. You decide when each of these periods begins and what you want your system to be doing.

And, Program Mode is flexible. If you leave or arrive home early, you can easily skip forwards to the next period. The program will take over again once the next time period begins.

### Intuitive user navigation

There is no need to display advanced functionality if it isn't required. You have the choice to view simple or advanced displays.

In simple display you can set your mode and temperature and let the MagIQtouch Controller do the rest!

Or, if you would like access to more advanced features, by touching 'More' you can select manual temperature mode, manual fan speed mode, or program mode and access other settings.



MAGIQTOUCH  
AIR SENSOR



### Optional

Allows you to mount your MagIQtouch Controller in the most convenient place in your home, because the MagIQtouch Air Sensor detects the temperature, not the Controller.

MagIQtouch Controller  
warranty



#### Intuitive user navigation

Simple and advanced display options.



#### Installation wizard

Steps the installer through the commissioning process for optimum operation.



#### Manual mode

Manually control temperature and/or fan speed settings.



#### Program mode

Settable 7 day, 4 time periods program, customisable to suit your lifestyle (including a temporary over-ride function).



#### Energy saving night quiet mode

When turned on, the Energy saving night quiet mode automatically reduces fan speed during the night for even greater economy and whisper quietness.



#### Date and time

Date and time displays appear on all operation screens.



#### Child access lock

Select a pin code to control access to your Controller.



#### About appliance

Displays information about your appliance including serial number, model number, and software version.



#### Adjustable working temperature range

Customise the temperature range displayed on the slider.



#### Status information

When this option is turned on, a temporary information display window becomes accessible on all Manual and Program screens to aid in troubleshooting.



#### Inbuilt diagnostics

If a fault is detected in the system, a fault message dialogue box will appear with information about the fault and some options to resolve the issue.



#### Service

The Service menu contains information and functions to assist service personnel. Access is locked with a service pin code.



#### Settings

Change the Controller and system settings to suit your requirements.



#### Screen Brightness Adjustment

Adjust the brightness of the screen when in standby mode, to suit your home and preference.



#### Simple Mode Lock

Lock the display in simple mode if you don't want to worry about advanced operating modes.



#### Program skip forward/back functionality

Ability to skip forward on the program if you arrive or leave home earlier than usual.

# Features and Benefits

## Breezair

### Non clogging water distribution

- Unique design ensures constant, even pad saturation
- Maximises the cooling effect - outperforms competitive products.



### Clean and dry function

- Automatic water draining when the system is not in use
- Prevents algae growth
- Avoids the seasonal maintenance required by competitive products.



### WaterMiser®

- Uses the minimum amount of water to achieve high efficiency cooling
- Water quality monitoring for significant water savings
- Leak detection monitor.



### Hushpower® direct drive InvertaCool motor

- Exclusive to Breezair
- Incredibly quiet and efficient throughout operating range
- Uses far less energy
- Unsurpassed reliability
- Corrosion-proofed throughout.



### Tornado® pump

- Australian designed and manufactured
- Exceptional reliability in extreme conditions.



### Long life Chillcel® pads

- Honeycomb design optimises the cooling effect
- Durable design outlasts competitive products.



### New fan

- Combined motor and fan
- Ultra-quiet centrifugal fan
- Responsive to duct sizing and back-pressure
- Designed to deliver optimum air output.



### Weatherseal®

- Automatic sealing system
- Reduces draughts and dust
- Reduces need for winter cover.

### Mirage rooftop unit

- The Mirage models' raked-base design and low profile hugs the slope of your roof
- Virtually invisible from street-level.



### Power control module

- Advanced electronics ensure maximum efficiency
- Microprocessor constantly analyses water quality, water consumption and power output
- Smart, reliable and durable.



### Optional extras:

#### Firewall Auto-seal

- Helps prevent ember attack in bushfires
- Metal flap that isolates the cooler from the duct work
- When fitted, the Breezair unit complies with
  - Bushfire Attack Level rating BAL-LOW through to BAL-29 (AS3959)
  - The Building Code of Australia.

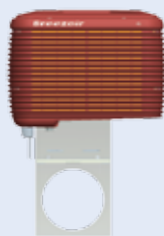

#### Firewall ember screen

- Helps guard against ember attack in bushfires
- Made from non-combustible mesh
- Maximum aperture of 2 mm
- Can be fitted to existing cooler pad frames
- Minimal reduction of air flow of 5%.

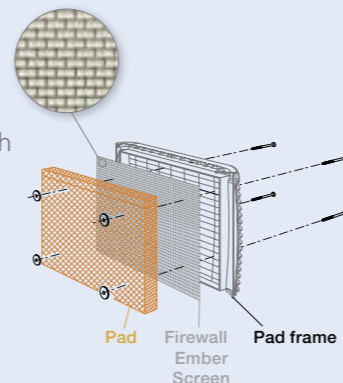

### Industry leading warranty and quality control standards

For complete peace of mind, a rigid quality control testing policy to Australian Standard ISO 9000 ensures that Breezair series air conditioners live up to their hard earned reputation for outstanding reliability.



For additional peace of mind, Breezair backs every one of its air conditioning systems with an industry leading comprehensive warranty program - including 7-year comprehensive warranty, 10-years on all structural components, plus a hefty 25-year cover on the Permatuf® cabinets.

### National service agent network

For your convenience and peace of mind, Seeley International has established a highly trained national network of approved Service Agents who are only a phone call away. Should you need to contact a Service Agent, please call 1300 650 644.

\*Exclusive from Seeley International dealers only.

# The Breezair Range

## Breezair Supercool



Enjoy superior cooling this summer with new Breezair Supercool! This incredible new range has super thick Chillcel pads, producing up to 20% more cooling when compared to the standard range. Breezair Supercool is only available from your Climate Masters of Seeley International specialist.

### Specifications



Model	EXS140	EXS160	EXS180	EXS200	EXS220
Nominal Power Motor (W)	500	550	750	1100	1500
Width (mm)	1160	1160	1160	1160	1160
Depth (mm)	1160	1160	1160	1160	1160
Height (mm)	660	860	860	860	860
Operating Weight (kg)	78	84	84	84	85
Cooling capacity (kW)*	8.0	11.0	12.8	13.7	14.1

\*The above data was drawn from Meridian Test Laboratory's test analysis. The testing was performed by a NATA accredited laboratory to the requirements of the Australian standard AS2913-2000 "Evaporative Air Conditioning Equipment." Achievable with ambient 38 °C DB, 21 °C WB, room temperature 27.4 °C.

**Supercool**  
DELIVERS UP TO 20% MORE COOLING

## Breezair Icon

### Specifications



Model	EXQ130	EXQ150	EXQ170	EXQ190	EXQ210	EZQ215**
Nominal Power Motor (W)	500	550	750	1100	1500	1500
Width (mm)	1160	1160	1160	1160	1160	1160
Depth (mm)	1160	1160	1160	1160	1160	1160
Height (mm)	660	860	860	860	860	1240
Operating Weight (kg)	78	84	84	84	85	94
Cooling Capacity (kW)***	6.5	9.4	10.6	11.4	12.3	12.9

\*Colours may vary.  
\*\*Model EZQ215 is available in slate grey and terracotta colours only.  
\*\*\*The Icon models have the same cooling output as previous years, however, our new NATA accredited testing laboratory has enabled us to be much more accurate when calculating cooling capacities and these latest cooling capacities will be reflected in the specifications of all Seeley International models as well as in the test results of all our competitors' models. The above data was drawn from Meridian Test Laboratory's test analysis. The testing was performed by a NATA accredited laboratory to the requirements of the Australian standard AS2913-2000 "Evaporative Air Conditioning Equipment." Achievable with ambient 38 °C DB, 21 °C WB, room temperature 27.4 °C.

# Features and Benefits MagIQtouch Controller – Harmony



Features	Benefits	Harmony EXQ, EXS & EZQ series
MagIQtouch Controller*	Smart, sophisticated and intuitive touch screen controller.	✓
Fan	Ultra-quiet centrifugal fan designed to deliver optimum air output.	✓
Fan speed	1 to 10 speed.	✓
Fan only	Operate the cooler in Fan Only mode (no water) to flush fresh air through the home and expel odours.	✓
Hushpower® direct drive InvertaCool motor	Exclusive to Breezair, the Hushpower motor is incredibly quiet and highly efficient throughout the operating range, using far less energy.	✓
Weatherseal®	Automatic sealing system to reduce draughts.	✓
Pre-wet function	When turned on, the Pre-wet Function will run the pump for a few minutes to allow the pads to be fully saturated before the fan is switched on, ensuring that only cooled air enters the home.	✓
Drain and dry	Automatically drains water from the tank when the system is not in use to prevent algae growth and obviate seasonal maintenance.	✓
WaterMiser®	WaterMiser monitors water quality to reduce consumption, minimise waste and eliminate unnecessary dumping of water. It also enables the minimisation of salt deposits throughout the unit. It drains salt laden water from the cooler to enable it to be replaced with fresh water, whenever it may be needed.	✓
Manual drain	Turns the cooler off and drains the tank.	✓
Pad flush	Ideal for bushfire prone areas, 'Pad flush' turns the cooler off and runs the pump continuously or for a set time.	✓
Auto re-start (optional)	After power outage, your cooler will automatically restart.	✓



# Seeley International

Seeley International is Australia's largest air conditioning and ducted gas heating manufacturer and a global leader in developing ingenious, energy-efficient cooling and heating products.

**Our vision is to lead the world in creating climate control solutions which continue to be highly innovative, of premium quality and inspirational in their delivery of energy-efficiency.**

But it's more than just a vision... it's a way of life!

A commitment to innovation and excellence is at the heart of all that we do. Our success in delivering on that commitment has been recognised by our many awards and our expanding global presence. Seeley International now exports to well over 120 countries. Not bad for a company that started out in 1972 in the garage of its founder and Executive Chairman, Frank Seeley AM FAICD, who was named South Australian of the Year for 2011!



\*Haier air conditioning products are proudly distributed by Seeley International throughout Australia.

For more information and current promotions\*  
find your nearest Climate Masters of  
Seeley International dealer at  
**[www.climatemastersofsi.com.au](http://www.climatemastersofsi.com.au)**  
**or call 1300 136 515**

\*Promotions are seasonal and do not run at all times of the year.

**Seeley International Pty Ltd**  
ABN 23 054 687 035

112 O'Sullivan Beach Road, Lonsdale, South Australia 5160

Phone (08) 8328 3850 Fax (08) 8328 3951

Email [marketing@seeleyinternational.com](mailto:marketing@seeleyinternational.com) [www.seeleyinternational.com](http://www.seeleyinternational.com)

Information in this brochure was correct at the time of preparation. E & OE



Quality  
ISO 9001  
SAI GLOBAL